

- 5 年 保 證
- CNC 精 確 加 工
- GSK & WIS 數 控 系 統
- 精 確 度: $0.5 \mu m$
- 精 確 度: $1.1 \times pn + 1 \mu m$
- 精 確 度: $1.5 \times pn + 1 \mu m$
- 精 確 度: $\pm 0.2 \mu m$
- 精 確 度: $1,000 \mu m$
- WRAS/KTW/NSF/FDA/ACS 證 書

Size	DN40-DN1200
Working Medium	Water
Temperature	0°C~70°C
Material	Ductile Iron/Stainless Steel/Cast Steel/Bronze/Aluminum Alloy
Design Standards	CJ/T 219 & JB/T 10674 & EN 1074-5
Pressure Level	PN10, PN16, PN25
Stress Test Standard	GB/T 13927 & ISO 5208 & EN12266-1
Flange drilling standard	GB17241.6; EN1092-2; ISO7005-2; ANSI / JIS / AS2129
Structure Length	GB 12221 & EN558-1

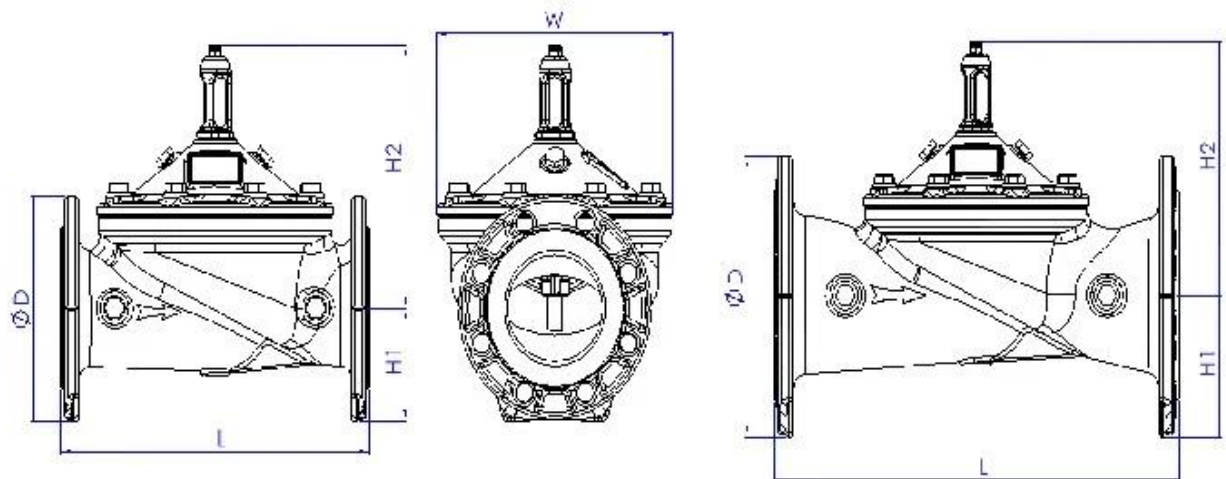



Exhibition Photos



TUV, API, WRAS, CE, ISO
DIN, ASME, BS EN, JIS, API, AWWA

?:
: RKSfluid 20 R&D 70