

DESIGN FEATURES

Features

1. Streamlined: minimum noise
2. Anti-static design
3. Double Block & Bleed
4. Automatic Self-Venting Seats
5. Emergency Protection

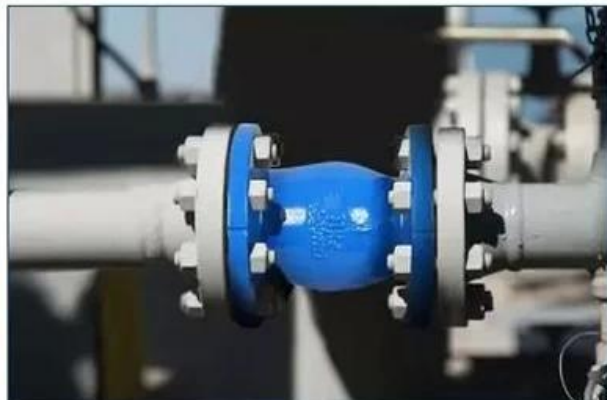
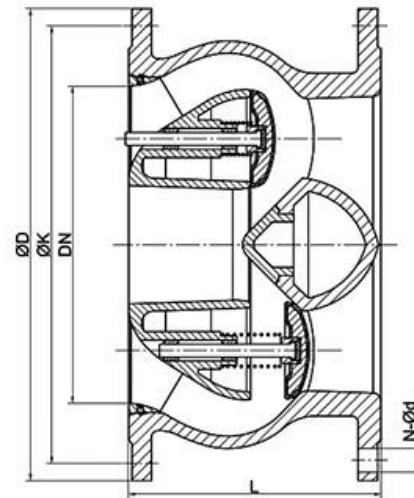
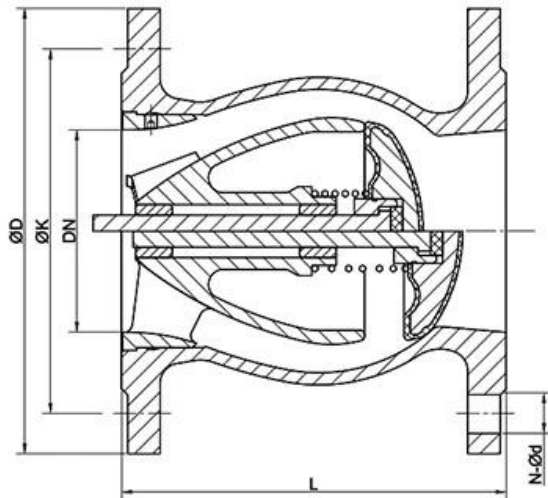

APPLICATION SCENARIO



Industrial water application



Power plant



Sea water desalination



Water treatment



Water supply and drainage



HAVC



Food and drug



Water transport



COMPANY INFORMATION



i 本公司拥有完善的质量管理体系，通过了 ISO 9001 质量管理体系认证，确保了产品质量的稳定性和可靠性。

ii 本公司拥有先进的 CNC 加工设备，能够满足各种复杂零件的加工需求，加工精度高，交货周期短。

unit 本公司拥有专业的技术团队，能够为客户提供专业的技术支持和售后服务，确保客户满意。

iv 本公司拥有完善的生产设备，能够满足大批量生产的需求，生产效率高。

v 本公司通过了 GB, ISO 9001, TUV CE, ADWO-2000, TS, PED, WRC WRAS, KTW, API 6D, API609 等认证。

VI 本公司拥有完善的质量管理体系，通过了 ISO 9001 质量管理体系认证，确保了产品质量的稳定性和可靠性。

01

21 years of professional experience

03

Independent research and development team
28 top senior professional researchers

05

100% high level ex-factory inspection

07

2 years quality assurance, repair and replacement

4 factories

02

2 professional testing centers

04

High quality imported materials

06

COMPANY QUALIFICATION



COMPANY EXHIBITION



